



Facet Aerospace Products, Co.

1048 Industrial Park Rd.
Bristol, Virginia 24201
(703) 669-5555

SERVICE BULLETIN

A1-88

DATE: August 1988

SUBJECT: Possible Loose 62-226 Pins

TIME OF COMPLIANCE: 30 Days

MODELS AFFECTED: MA4-5, MA-5 and MA 6 Series
Carburetors Manufactured After April 1984

There have been instances of the part number 62-226 Air Metering Stop Pin coming loose in the field.

Facet knows of no practical way to examine these carburetors in the field to determine the retention capacity of the P/N 62-226 Pin in the affected carburetors.

Therefore, Facet will provide a kit with a new pin on a no charge basis to perform a modification to the affected carburetor that will insure the retention of the pin.

The following carburetors manufactured after April 1984 are affected.

Part No. 10-3878 Used on Lycoming Model O-360

Serial No. G-54-11129 thru G-54-11136
G55-11500 thru G-55-12064

Part No. 10-4164-1 Used on Lycoming Model O-360

Serial No. K-49-9001 thru K-49-9023

Part No. 10-4218-1 Used on Lycoming Model VO-540

Serial No. AK-37-3002

Part No. 10-4401-1 Used on Lycoming Model VO-540

Serial No. AC-38-3278 thru AC-38-3298
AC-40-4001 thru AC-40-4021

Part No. 10-4404 Used on Lycoming Model O-540

Serial No. R-48-11501 thru R-48-11721

Part No. 10-4404-1 Used on Lycoming Model O-540

Serial No. R-45-11005 and R-45-11007
AC-45-11000 thru AO-45-11101

Technical Aspects Are FAA Approved

Part No. 10-4438-1 Used on Lycoming Model TVO-435

Serial No. AH-29-6000 thru AH-29-6009

Part No. 10-5054 Used on Lycoming Model O-540

Serial No. BZ-16-3000 thru BZ-22-3110

Part No. 10-5193 Used on Lycoming Model O-360

Serial No. CP-5-3500 thru CP-5-3967

Part No. 10-4893 Used on Continental Model O-470

Serial No. BD-5-10000

Part No. 10-4893-1 Used on Continental Model O-470

Serial No. CL-4-3700 thru CL-7-3776

Part No. 10-5284 Used on Continental Model O-470

Serial No. DV-0-500 thru DV-0-505
DV-1-1000 thru DV-1-1392

Part No. 10-4865 Used on Franklin Model 6A-350

Serial No. BC-33-5001 thru BC-33-5005

If the lower portion on the name plate on your carburetor is stamped with a P you may ignore this bulletin.

If your carburetor is one that is affected immediately notify Facet of the Part Number and Serial Number and a Modification Kit will be air shipped to you, or return the carburetor prepaid freight to Facet, the modification will be made and the carburetor returned.

When the modification has been completed stamp or etch a P on the lower portion of the carburetor name plate and make an aircraft log book entry to indicate compliance.

"When referring to aircraft carburetor serial numbers, disregard the center number, as this is used for our internal blueprint control only."

Example: Carburetor A10-3965-12 may have a serial number like this:

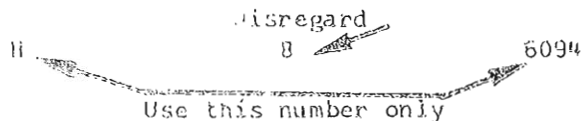

INSTALLATION INSTRUCTIONS FOR CARBURETOR MODIFICATION KIT
SERVICE BULLETIN A1-88

KIT PART DATA

666-940		Applies to P/N's 10-3878, 10-4164-1, 10-4404, 10-4404-1, 10-4893, 10-4893-1, 10-5054, 10-5193, 10-5284
M-141	(1)	Gage
M-542	(1)	Tool
16-A31	(1)	Gasket - Throttle Body to Bowl
16-A56	(1)	Gasket - Air Metering Pin Plug
16-B44	(1)	Gasket - Pump Idler Screw
62-F1	(1)	Pin - Air Metering Pin Stop
66-20	(1)	Lockwire - Air Metering Plug
78-A97	(6)	Washer - Throttle Body to Bowl Screw
82-1	(1)	Pin-Cotter - Pump Idler Screw
82-11	(1)	Pin-Cotter - Float Shaft
666-941		Applies to P/N's 10-4218-1, 10-4401-1, 10-4438-1, 10-4865
M-141	(1)	Gage
M-542	(1)	Tool
16-B12	(1)	Gasket - Throttle Body to Bowl
16-A56	(1)	Gasket - Air Metering Pin Plug
16-B44	(1)	Gasket - Pump Idler Screw
62-F1	(1)	Pin - Air Metering Pin Stop
66-20	(1)	Lockwire - Air Metering Plug
78-A97	(6)	Washer - Throttle Body to Bowl Screw
82-1	(1)	Pin-Cotter - Pump Idler Screw
82-11	(1)	Pin-Cotter - Float Shaft

With the carburetor removed from the engine and referring to the appropriate carburetor part number exploded view and parts list in the Facet Aircraft Carburetor Service Manual:

Remove the 66-20 Lockwire and the 80-151 Air Metering Plug.

Remove the 49-XXX Air Metering Jet and the 173-XXX Air Metering pin.

Remove the throttle body to bowl screws and carefully separate the throttle body and carburetor bowl.

To prevent damage remove the float, accelerator pump plunger and the throttle body to bowl gasket.

Drive out the 62-226 Air Metering Stop Pin from the top flange of the carburetor.

Lubricate the Gage M-141 and insert in the air metering channel completely (Fig. 1) insuring that the small end of the gage is visible under the hole created by removal of the 62-226 Air Metering Stop Pin.

With the counterbore Tool M-542 in a hand chuck or a slow variable speed drill motor carefully insert the pilot of the M-542 Tool in the air metering stop pin hole (Fig. 1) and rotate clockwise applying very light pressure until the pilot of the counterbore Tool M-542 contacts the Gage M-141. Stop, this controls the depth of the counterbore and the position of the 62-F1 Pin.

DO NOT ATTEMPT TO DO THE ABOVE IN A DRILL PRESS. The air metering stop pin hole will be damaged. It is drilled at an angle to the flange.

Remove the M-542 Tool. Make certain that the throttle body is clean and free of machining chips.

Start the 62-F1 Air Metering Stop Pin in the stop pin hole and apply a coating of loctite grade 272 or equivalent to the 62-F1 Pin. Continue pressing in until the 62-F1 Pin is seated in the newly formed counterbore (Fig. 2). Use a center punch to stake the casting 4 places around the head of the 62-F1 Pin.

Remove the Gage M-141. Reinstall the 49-XXX Air Metering Jet and the 173-XXX Air Metering Pin and adjust per instructions in the Aircraft Carburetor Service Manual.

Make certain that the 173-XXX Air Metering Pin is retained by the 62-F1 Air Metering Stop Pin.

Cycle the throttle shaft several times between full closed and full open to confirm free rotation.

Reassemble the carburetor per instructions in the Facet Aircraft Carburetor Service Manual.

Stamp or etch a "P" on the lower portion of the carburetor name plate to indicate compliance.

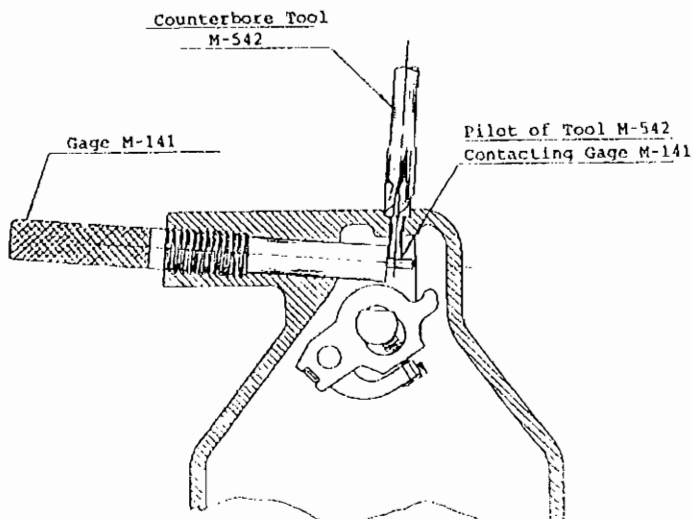

FIG. 1

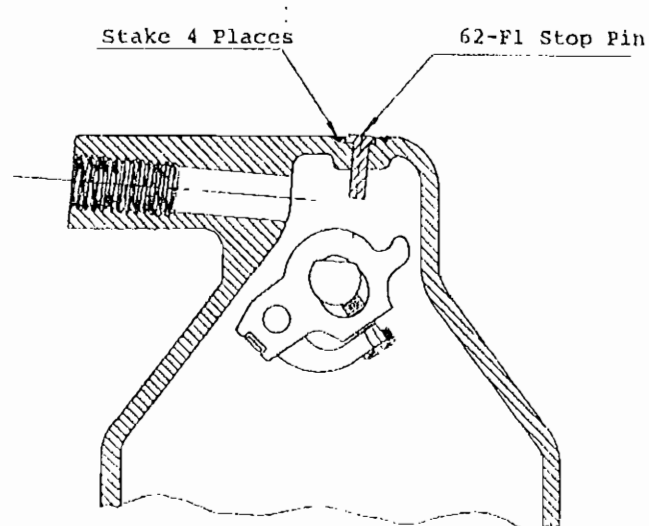

Fig. 2